

OnSite™ 23"/10U Wall Rack

Model WR-10U23

1. OVERVIEW	1
2. APPLICATIONS.....	1
3. DESCRIPTION	2
4. INSTALLATION	2
5. TESTING AND TROUBLESHOOTING	4
6. CUSTOMER SERVICE.....	5
7. WARRANTY & REPAIRS	5
8. SPECIFICATIONS.....	5

1. OVERVIEW

Engenuity's OnSite™ Model WR-10U23 (Figures 1 and 2) is a wall-mounted equipment rack that supports up to ten 23-inch rack units (10U) in a compact footprint. Cable management options include side-mounted guides for cable grooming and take-up reels for cable slack. The carrier-class assembly is an ideal fit for equipment rooms, cabinets, or customer premises locations.

Document Status

This document has been reissued to include instructions for using the drill template.

Product Features

- 10U height for 23-inch rack-mounted equipment
- Easily installed on a wall or backboard
- Welded, carrier-class design
- Optional side-mounted cable guides and take-up reels
- Reduces wall space requirements for multi-chassis applications
- Symmetrical frame design enables mounting with ground connections facing upward or downward

2. APPLICATIONS

For service delivery, the WR-10U23 allows carriers to securely wall mount rack-based equipment in equipment rooms, cabinets, or on customer premises. The WR-10U23 offers the following technician-friendly solutions:

Rack-Mount Compatibility

The WR-10U23 supports any combination of standard 23-inch rack-based equipment, up to a total of ten rack

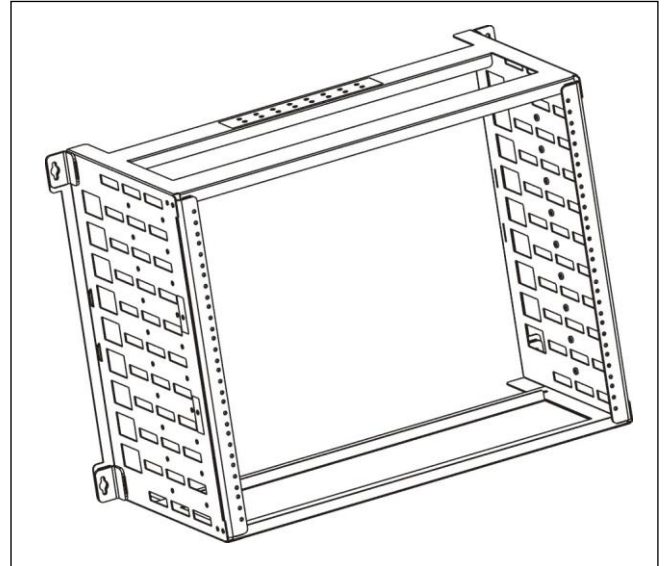

Figure 1. WR-10U23 Wall Rack

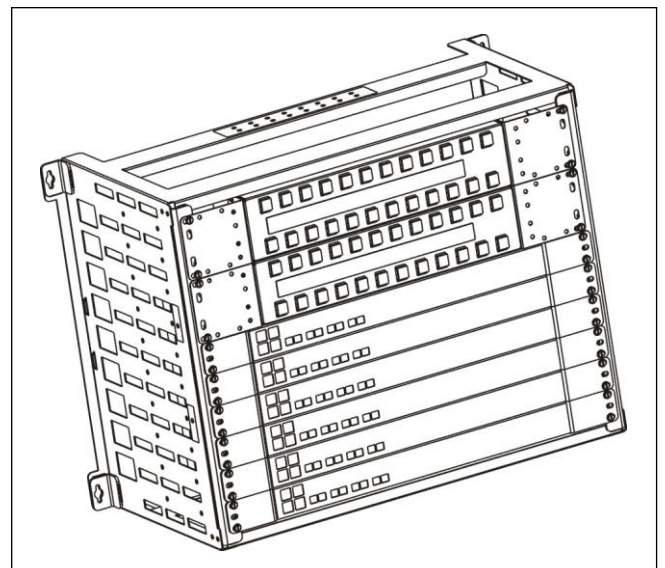

Figure 2. WR-10U23 w/ equipment installed (example)

units high. The mounting arrangement provides the density benefits of a floor rack, but in a compact wall-mounted footprint that requires only a single technician to install.

Cable Management

Cable guides can be installed on either side of the WR-10U23 to groom cables from the front of each equipment chassis back to the wall. A package of five cable guides is available as Model CG-5.

A side plate with cable take-up reels, Model SPL-4H, can be added to store excess cable length being fed to installed equipment. The SPL-4H mounts to either side of the WR-10U23 and includes two adjustable, split reels.

3. DESCRIPTION

The WR-10U23 (Figure 3) features welded steel, carrier-class construction. The front of the frame provides two vertical rails with standard threaded hole spacing for up to ten rack units. Eight pairs of threaded grounding holes and pre-installed screws are provided on the rear crossbar for attachment of ground lugs. One pair of holes supports grounding of the WR-10U23 itself and the other seven pairs of holes support ground connections from installed equipment. The unpainted grounding area provides metal-to-metal contact with ground lug surfaces.

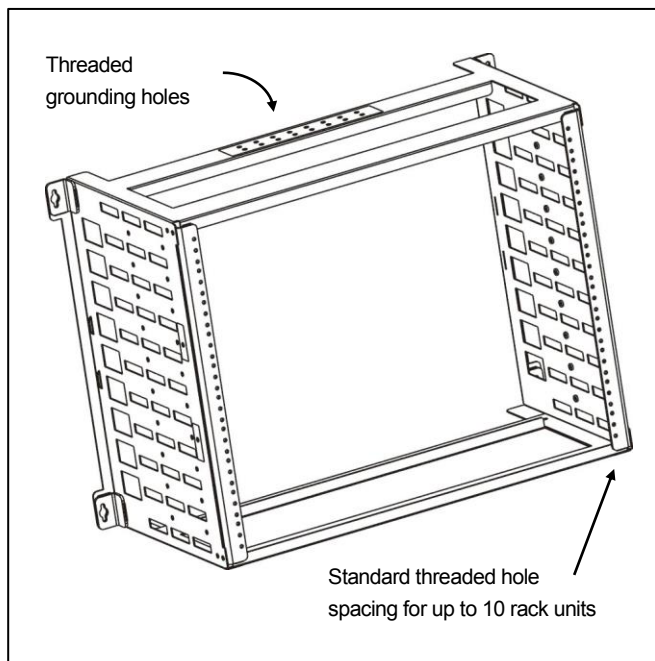

Figure 3. WR-10U23 Features

Cable Guides

Optional cable guides with removable covers (Figure 4) can be attached to either side of the WR-10U23 frame. Up to ten cable guides can be installed per side.

Side Plate with Take-up Reels

An optional side plate, Model SPL-4H (Figure 5), provides two adjustable cable take-up reels. The reels are sized to maintain proper bend radius in fiber applications. The

metal plate can be attached to either side of the WR-10U23 frame using the included hardware.

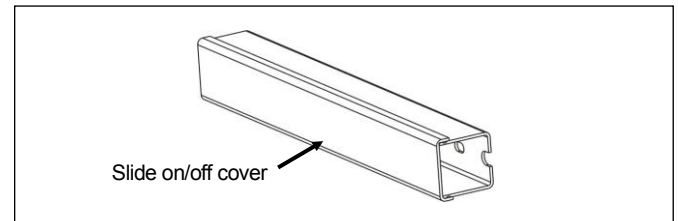

Figure 4. Cable guide

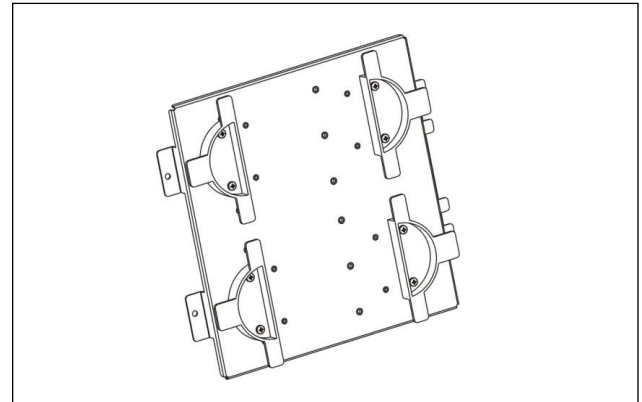

Figure 5. Model SPL-4H Side Plate

4. INSTALLATION

The WR-10U23 shipping carton contains the following:

- Pre-assembled mounting frame
- Six (6) #12 x 1" slotted hex screws, self-tapping
- Product documentation
- Drill template

Installation steps are described in detail below.

A. Mounting frame

- ① Select an appropriate location on a wall or backboard to install the mounting frame. Choose a mounting surface and hardware that can support the combined weight of the mounting assembly and equipment that is to be installed. Mounting to a 3/4" thick backboard with #12 x 1" screws is recommended. Maximum weight holding capacity of the WR-10U23 is 200 lbs.
- ② Determine the desired orientation of the ground lugs. The symmetrical design of the WR-10U23 frame allows it to be installed with the grounding holes facing upward or downward.
- ③ Tape the drill template to the wall ensuring it is level. The drill template provides information for multiple wall

mounted racks. Be sure to use the hole symbol \textcircled{D} . Drill six (6) 3/16" pilot holes. These holes mate with the mounting brackets located at the corners of the frame. The frame will be fastened with two screws in each of the upper brackets and one screw in each of the lower brackets, as shown in Figure 6.

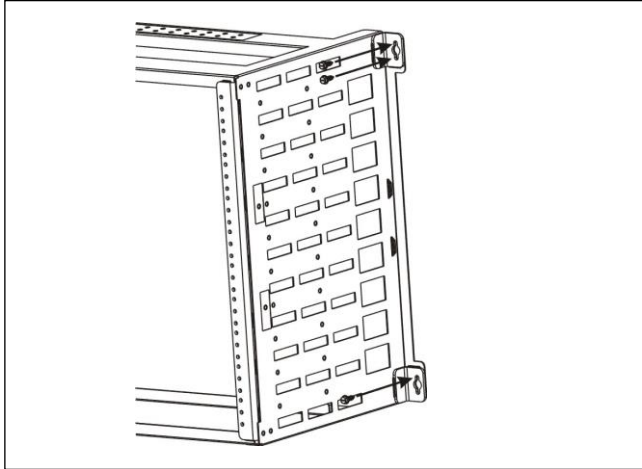

Figure 6. Mounting screw locations

- ④ Before attempting to fasten the mounting frame to the wall, insert a screw into the top pilot hole on either the left or right side. Partially thread the screw into the hole, leaving the screw head approximately 1/4" from the surface.
- ⑤ Hold the mounting frame against the wall while resting the cutout of the bracket on the installed screw. Align the other five mounting holes and install a screw in each hole. Tighten all six (6) screws securely.

B. Frame grounding

- ① Locate the eight (8) pairs of pre-installed grounding screws with lock washers on the crossbar of the frame. The grounding screws are 10-32 x 3/8" on 5/8" centers.
- ② Install a dual ground lug (customer provided) with holes on 5/8" centers beneath the included screws and washers on one pair of grounding holes. Tighten the screws to fasten the lug to the mounting frame. The example in Figure 7 illustrates the frame positioned with grounding screws facing downward.
- ③ Connect a ground wire of appropriate gauge to the ground lug and attach the other end of the wire to a bonded ground point, per local procedures for network equipment.

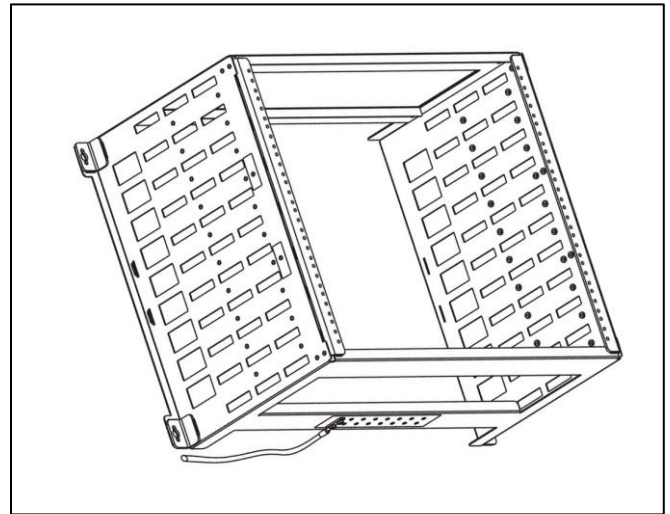

Figure 7. Frame grounding example

C. Equipment Installation

- ① Install rack equipment with 23" hole spacing by carefully sliding the chassis through the front of the WR-10U23 and aligning chassis mounting ears with the threaded holes in the rails of the WR-10U23 frame. Insert and tighten #12-24 machine screws (customer provided) on each side of the chassis. An example of a fully populated wall rack is shown in Figure 2.
- ② Attach ground lugs associated with each equipment chassis to the threaded ground holes on the WR-10U23 crossbar as needed.

D. Optional Cable Guide Installation

- ① To install a cable guide to the side of the mounting, first remove the sliding cover from the cable guide. Insert two of the #10-32 x 3/8" screws (included in CG-5 package) through the cable guide and into the threaded holes on the side of the WR-10U23 frame (Figure 8).
- ② Groom cabling from the front of the chassis to the wall through the cable guide on the side of the WR-10U23, as shown in Figure 9, and replace the sliding cover.

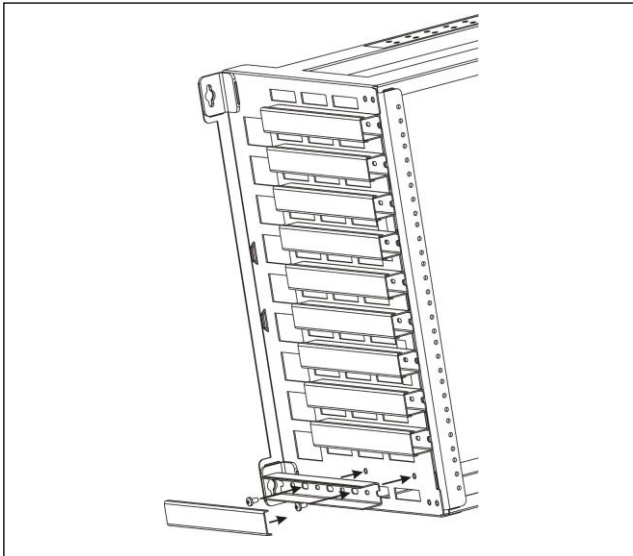

Figure 8. Cable guide installation

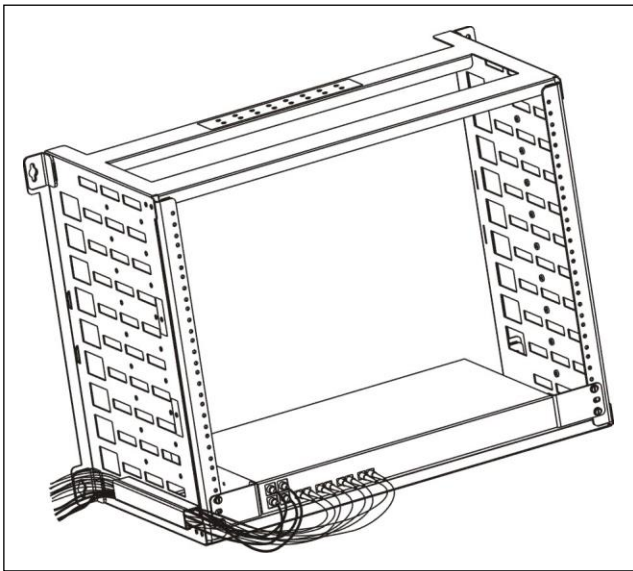

Figure 9. Cable guide application

E. Optional Side Plate Installation

Threaded holes on both sides of the WR-10U23 frame allow an optional side plate (Model SPL-4H) or additional cable guides to be installed to expand cable management. The SPL-4H provides two split and adjustable take-up reels, as illustrated in Figure 5.

To install and use the SPL-4H side plate, refer to Figure 10 and the steps below.

- ① Slide the two narrower tabs at the edge of the SPL-4H into the openings on the side of the WR-10U23, toward the rear of the mounting.
- ② Align the wide tabs at the front edge of the SPL-4H with the threaded holes on the side of the WR-10U23

frame. Use the two (2) included #10-32 x 3/8" screws to securely fasten the side plate to the frame.

- ③ Carefully wrap cables around the take-up reels to reduce slack as needed. Example routing is shown in Figure 11. Alternate mounting holes are included on the side plate for repositioning the half-reels, if desired.

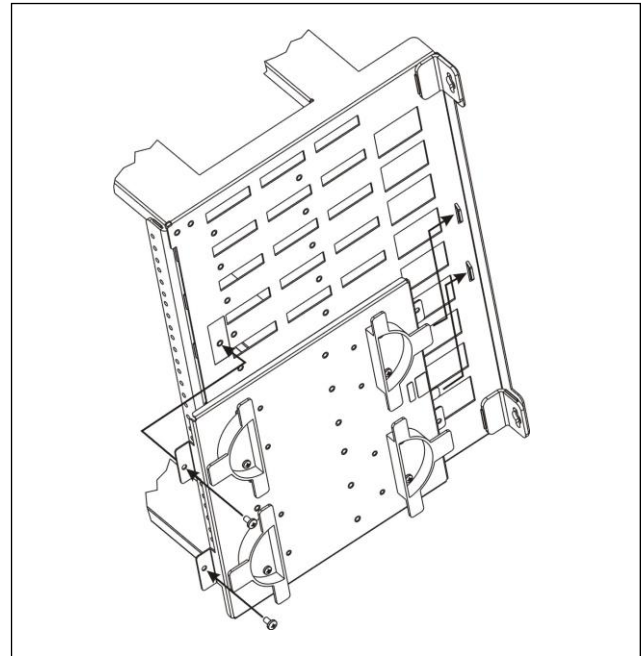

Figure 10. SPL-4H installation

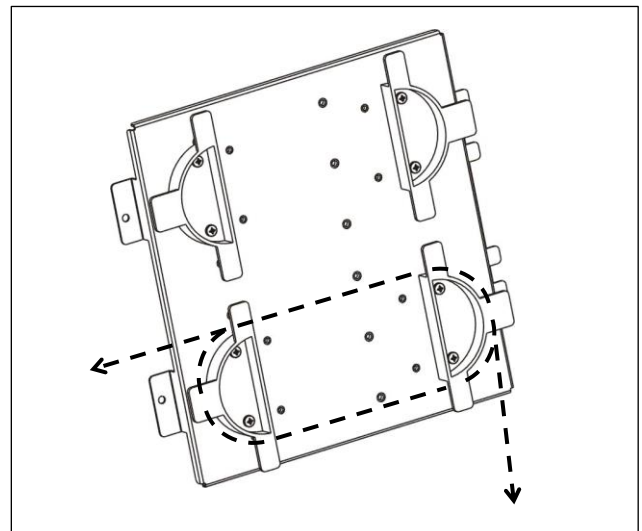

Figure 11. Cable take-up reel routing

5. TESTING AND TROUBLESHOOTING

Equipment installed in the WR-10U23 should be tested according the manufacturer's instructions.

6. CUSTOMER SERVICE

If technical or customer assistance is required, please contact Enginuity at the following:

Customer Service	1-800-980-3266 sales@enginuitycom.com
Technical Support	1-800-841-1005 support@enginuitycom.com
Enginuity Communications 3545 Stern Avenue St. Charles, Illinois 60174 www.enginuitycom.com	

7. WARRANTY & REPAIRS

Warranty

Enginuity warrants this product for one (1) year from date of purchase. Any attempt to repair or modify the equipment by anyone other than an authorized Enginuity representative will void the warranty.

This limited warranty does not cover any losses or damages resulting from shipment to or from the customer, or from improper installation, abuse, modifications, or unauthorized repair by other than Enginuity personnel.

Repair and Return

Enginuity equipment will be repaired or replaced without cost during the warranty period if the product is defective for any reason other than abuse, improper use, or improper installation. Before returning defective equipment, first request a Return Material Authorization (RMA) number from Enginuity. Once an RMA number is obtained, return the unit, freight prepaid, along with a brief description of the problem, to:

Enginuity Communications
3545 Stern Avenue
St. Charles, Illinois 60174
ATTN: Repair & Return Dept.

Replacements will be shipped in the fastest manner consistent with the urgency of the situation. Repair or replacement of faulty equipment beyond the warranty period is available for a nominal charge.

8. SPECIFICATIONS

Mounting Frame

Part Number	WR-10U23
Description	OnSite™ 23"/10U wall rack
Dimensions (H x W x D)	19.25 x 26.7 x 12.6 inches
Weight	14.8 pounds
Capacity	10 rack units, total installed equipment weight not to exceed 200 lbs.
Operating Temperature	0 to 50°C
Standards Compliance	Meets applicable Telcordia NEBS requirements, including Zone 4 seismic.

Optional Side Plate

Part Number	SPL-4H
Description	Side plate for wall rack with (2) adjustable take-up reels
Dimensions (H x W x D)	10.5 x 11.3 x 1.3 inches
Weight	2.5 pounds

Additional Cable Guides

Part Number	CG-5
Description	Pack of (5) cable guides for wall rack
Dimensions (H x W x D)	1.0 x 1.3 x 7.8 inches (each)
Weight	2.0 ounces (each)