

LOC-DROP[®] Fiber Drop Repair Enclosure

Model LOCDROP-EN

Patent Pending

1. OVERVIEW.....	1
2. APPLICATIONS.....	2
3. DESCRIPTION.....	2
4. INSTALLATION.....	2
5. CUSTOMER SERVICE.....	6
6. WARRANTY & REPAIRS.....	6
7. SPECIFICATIONS.....	7

1. OVERVIEW

Engenuity's LOC-DROP Model LOCDROP-EN enclosure (Figures 1 and 2) is a rugged plastic enclosure optimized for splicing or demarcation of fiber optic subscriber services. Inside, there are slots to hold a splice chip and an area to hold a fiber coupler, internal fiber management with bend control, and two strength member clamps. A trace wire tie-down is provided on the exterior of the enclosure.

The LOC-DROP enclosure is engineered with a robust strength member clamp assembly to capture and retain the fiber drop cable's two strength members. It is **IMPORTANT** for the strength members to be inserted in the grooves between the Upper and Base Clamps (Figure 3). DO NOT place strength members directly under the washer. This will ensure the maximum cable retention performance for the cable under environmental and handling stresses.

This compact enclosure may be directly buried or mounted to a pole or wall. With optional brackets, it may also be hung from a strand.

Document Status

This document has been reissued to provide additional clarity of strength member installation.

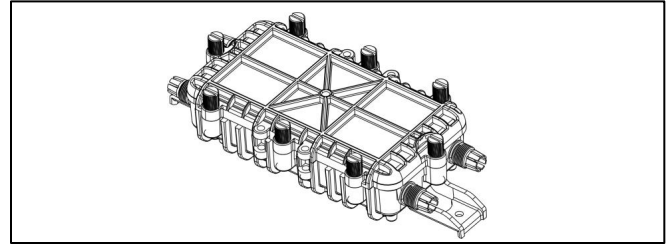

Figure 1. LOCDROP-EN

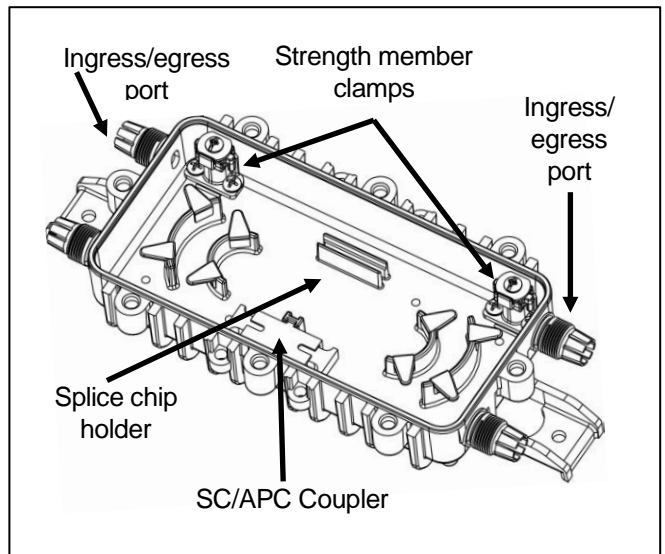

Figure 2. LOCDROP-EN interior

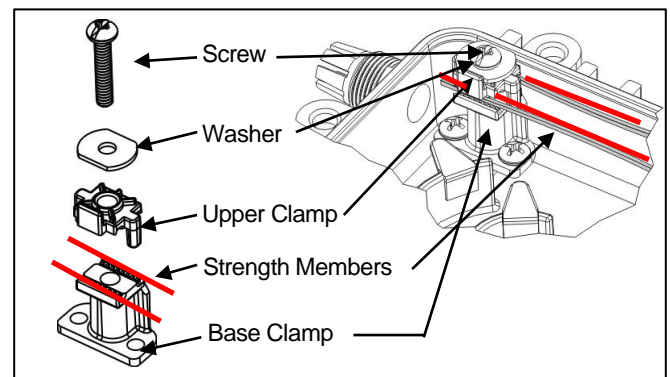

Figure 3. **Strength members MUST be placed between the Upper and Base Clamps**

Product Features

- Weather-tight
- Compact, rugged design
- Integrated fiber management features
- Integrated splice chip holder
- SC/APC coupler
- Optional strand mount brackets

2. APPLICATIONS

The LOC-DROP enclosure is ideal for fiber drop cable repair by protecting spliced fibers.

The LOCDROP-EN is rugged enough for direct burial, but also provides integral ears for wall or pole mounting. Additionally, optional brackets allow the LOCDROP-EN to be hung from a strand.

3. DESCRIPTION

The LOCDROP-EN enclosure features two ingress/egress ports. The associated strength member clamps are located at opposite ends from the ingress/egress ports to allow for easier access. There are internal fiber management features to assist with fiber slack storage and to support and protect 900-micron fiber. An integrated splice chip holder and an SC/APC fiber coupler provide flexibility for splicing or connection. A trace wire tie-down is located on the exterior of the enclosure to assist with maintaining tracing continuity during locating operations. The LOCDROP-EN is held tightly closed with captive thumb screws.

Each LOCDROP-EN includes the following:

- One enclosure
- Two packs of nuts and grommets for use with FastAccess® /figure 8 style fiber optic cable
- Two packs of nuts and grommets for use with flat drop/oval style fiber optic cable.
- One SC/APC coupler, installed

The LOC-DROP family of products includes:

- LOCDROP- EN – the basic enclosure described in this practice.
- LOCDROP-2SCAPC – a pair of LOC-DROP enclosures connected by pre-installed micro-armored cable on a fiber spool (51.5 ft). The strength members come tied in place, and each end of the fiber is terminated with an SC/APC connector inserted into an SC/APC coupler.

- LOCDROP-SM – a pair of strand mount brackets and associated hardware for strand mounting a LOC-DROP enclosure.

4. INSTALLATION

The key to delivering watertight and robust LOC-DROP enclosure relies on two elements:

- The proper combination of cable grommets and enclosure port nuts, based upon the user's selected fiber drop cable. The LOC-DROP enclosure offers two styles of cable grommets paired with appropriate port nuts to support common subscriber drop cables used in FTTH / FTTP installations. Table 1 outlines the correct combination of grommets and nuts based upon common drop cable constructions.
- The proper attachment of the drop cable's strength members to the LOC-DROP's strength member clamps, Figure 9.

Fiber Cable Preparation

- ① Mark cable as shown in Figure 4 at point A.
- ② If cable includes a trace wire, mark the cable as shown in Figure 4 at point B. Peel the trace wire to point B. Place some sleeving or electrical tape around the cable to keep the trace wire from continuing to separate.
- ③ For Flat Drop cable, use a fiber splitter tool (Jonard FOD-2000 or company approved tool) to score the cable jacket to the mark shown in Figure 4, point A. Do not remove the jacket at this time (to protect fiber during installation).
- ④ For FastAccess cable, strength members can be split after cable has been inserted into housing (to protect fiber during cable installation).

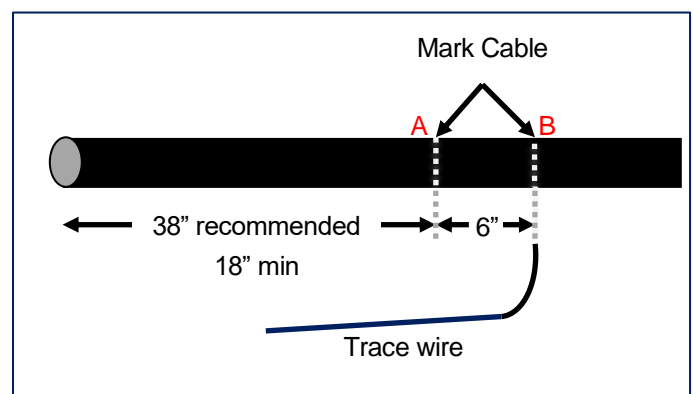



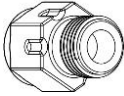

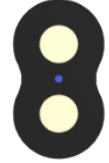

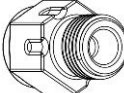

Figure 4. Fiber cable preparation

Nut and Grommet Installation

- ① Select one of the enclosures. Detach the top cover by unscrewing the thumb screws.
- ② Referring to Table 1, select the grommet and port nut from the parts bags that most closely matches the fiber cable shape.

NOTE: Use of the wrong grommet/nut combination will significantly reduce weathertightness of the enclosure.

Table 1. Grommet and port nut combinations

Drop Cable Type	Cable Profile	Grommet	Nut
Flat Drop – oval style			  large opening
FastAccess® – figure 8 style			  small opening

- ③ Referring to Figure 5 to ensure proper orientation, slide the nut onto the cable past the first mark. Follow with the grommet sliding it up to the first mark. Dampening the cable with water can assist with sliding the grommet onto the cable.

NOTE: Be sure the port nut and grommet are facing in the correct direction.

NOTE: Ensure the cable is cut cleanly to prevent possible damage of the grommet.

NOTE: If strand mounting, add the strain relief boot provided in LOCDROP-SM strand mount kit before the nut.

- ④ Feed the drop cable into a housing port until the grommet reaches the ingress/egress port. Grip the grommet and cable. Using a push/twist motion, insert the grommet into the port until the grommet's flange is

seated against the end of the port. Dampening the grommet with water will assist with insertion.

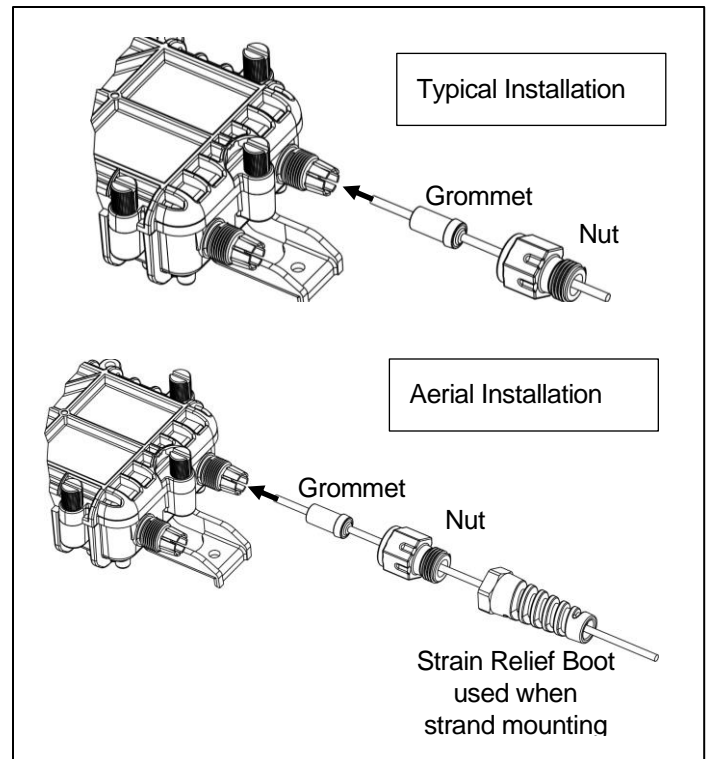

Figure 5. Fiber installation at ingress port

- ⑤ Thread the nut onto the end of the port. As the nut begins to tighten against the grommet, push the cable until the mark is 1/2 inch inside the housing (Figure 6). Then, finish threading the nut until it just touches the housing's exterior. Tighten the Strain Relief Boot, if used.

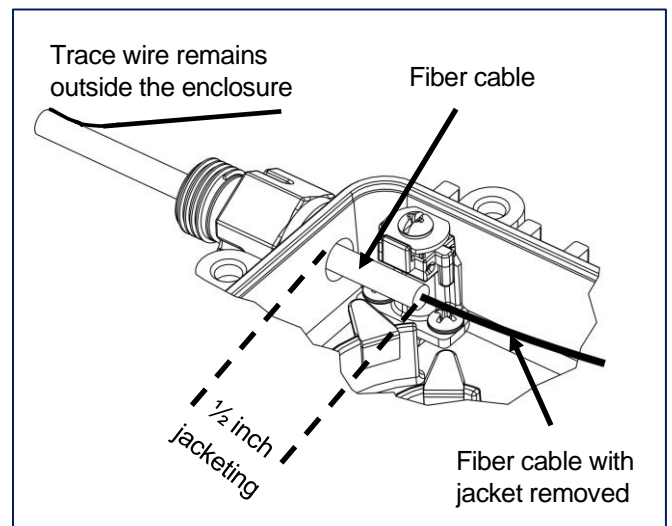

Figure 6. Proper placement of fiber cable

- ⑥ Repeat installation procedure for the second drop cable.

Preparing Cable Installed Inside Housing

Based on the drop cable construction, do the following:

For Flat Drop Cable (Figure 7)

- ① Remove the previously slit cable jacket, trimming off at the mark on cable, exposing the strength members and central fiber tube. Trim the strength members to approximately 7".

For FastAccess Drop Cable (Figure 8)

- ① Split the strength members to the mark on the cable, separating the plastic covered strength members from the central fiber. Trim the strength members to approximately 7".

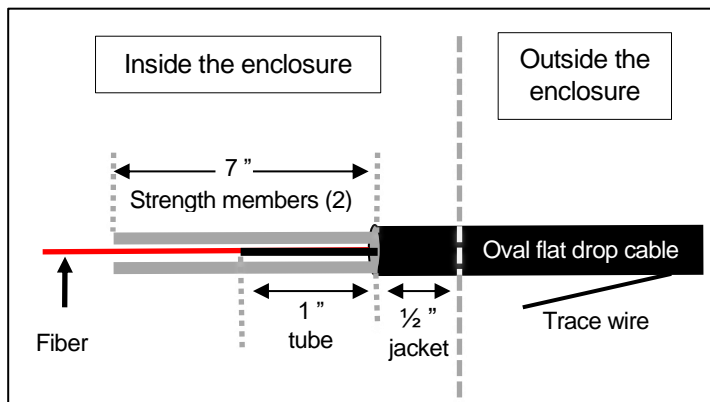

Figure 7. Flat Drop cable / strength member preparation

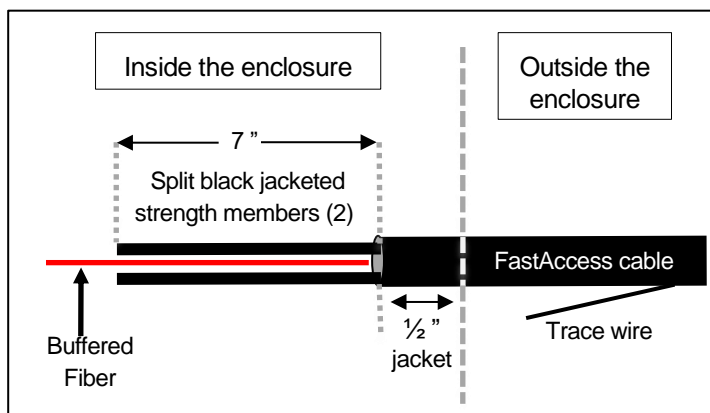

Figure 8. FastAccess drop cable / strength member preparation

Preparing and Securing Strength Members

The drop cable's strength members are secured to the LOCDROP's strength member clamp located on the **opposite** side from the cable's entry point.

The LOCDROP strength member clamp assembly (Figure 9) is constructed of four components: Base Clamp, Upper Clamp, washer, and screw.

NOTE: It is important to insert the fiber cable's strength members between the Upper Clamp and Base Clamp (not directly underneath the washer).

- ① Loosen the screw on the top of the strength member clamp so it protrudes approximately 1/4-inch. Lift up from the upper clamp to open a gap between the Upper and Base Clamps.
- ② Referencing Figure 9, lay the two strength members between the Upper Clamp and Base Clamp, ensuring the two strength members are positioned in the toothed grooves. Tighten the screw to a torque of 10-12 in-lbs.
- ③ Trim the excess strength member.
- ④ Repeat for the second drop cable.

Connecting, Routing and Storing Fibers

The LOCDROP enclosure provides storage for up to two single fusion splices or a single SC bulkhead adapter for use with field installable connectors. The integrated bend radius control and storage features are designed for both 250 and 900 micro buffered fibers.

- ① If using FLAT drop cable with central fiber tube, remove the central fiber tube, exposing the inner fiber before routing and storing in the housing. Leave approximately 1" of exposed tubing (Figure 7).
- ② Remove and set-aside the SC bulkhead adapter.
- ③ Temporarily route the fiber around the bend radius controls, approximately three revolutions, until it reaches a position to allow either fusion splicing or termination using field installable connectors. Mark and trim the fiber to length.
- ④ Prep the fiber for splicing or for terminating to a connector using approved company practices.
- ⑤ Route the fibers around the fiber management features and store the fusion splice protection sleeve in the holder or re-install the SC bulkhead adapter into its holder, then clean and insert the fiber connectors into the adapter.

When necessary, use both the inner and outer bend control features to take up fiber slack. Keep fibers below tabs and retained in the housing.

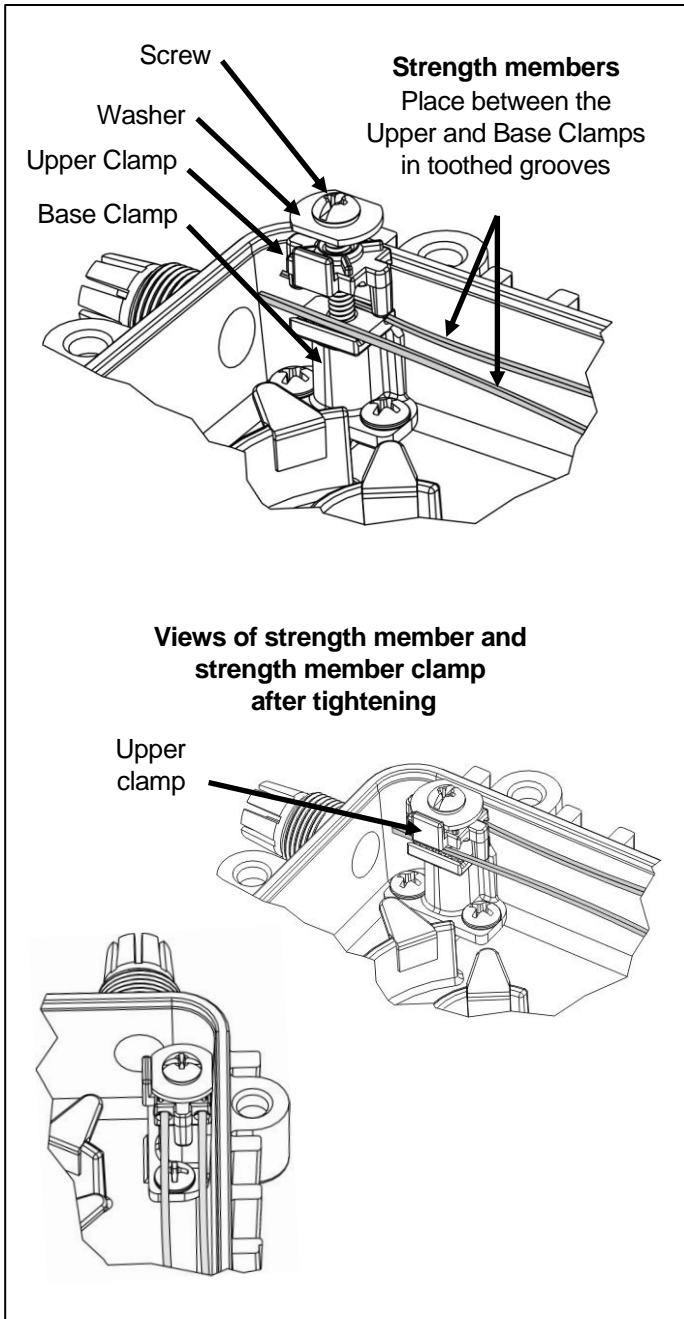

Figure 9. Strength member clamp

Closing the LOC-DROP Housing

- ① Ensuring there are no loose fibers, place the LOC-DROP cover onto the base.
- ② Start by finger tightening all the screws. Then, using a flat head screwdriver, starting at one of the long-side

center screws, begin tightening down the screws using a star tightening pattern. Tighten screws 2-3 times until screws no longer tighten (min. 20 in-lbs).

Trace Wire Attachment

- ① Loosen the screw for the trace wire located on the bottom side of the LOC-DROP enclosure.
- ② Cut the trace wire to length so that it reaches the screw + 2 inches. Strip the insulation so that approximately 0.75 inches of copper is exposed. Loop the wire around the screw as shown in Figure 10.
- ③ Tighten the screw.

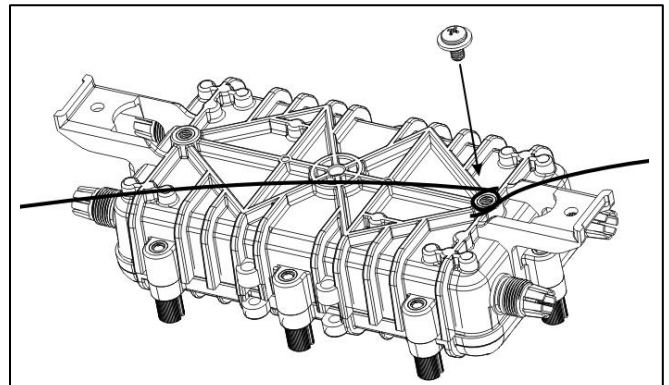

Figure 10. Trace wire attachment

Strand Mounting Brackets Installation

The optional LOCDROP-SM kit includes two brackets and the hardware needed to attach the brackets to the LOC-DROP enclosure and hang from a strand.

- ① Attach the brackets to the enclosure as shown in Figure 11.
- ② Place brackets over the strand and tighten bolts using a 216 tool or wrench as shown in Figure 12.
- ③ Be sure to place the strain relief boots on the fiber optic cable as shown in Figure 5 before feeding cable into the LOCDROP enclosure.

Adding A Tag and Other Options

The LOCDROP enclosure provides two sets of rings (Figure 13). These rings may be used to attach a locator tag or ID label.

For aerial applications, it is recommended that one or two cable ties (user provided) be used in these locations to tether the top of the enclosure to the base when opening.

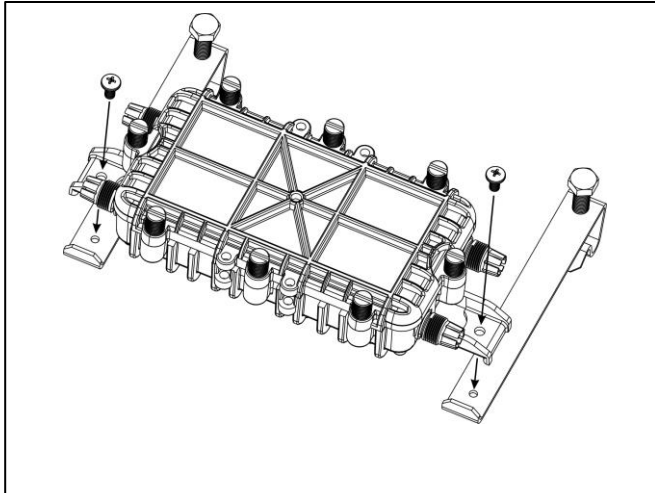

Figure 11. Strand mount kit installation

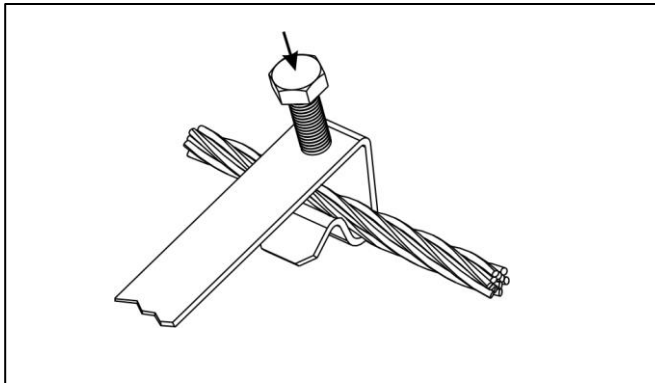

Figure 12. Securing to a strand

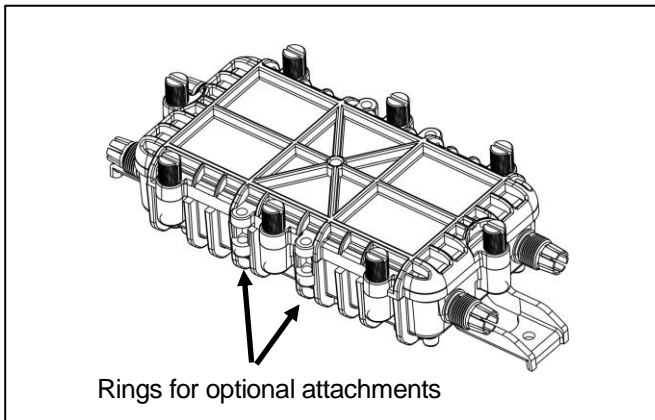

Figure 13. Rings for Optional Attachments

5. CUSTOMER SERVICE

Customer Sales and General Support

Monday through Friday, 8:00 a.m. – 5:00 p.m. CST
 Toll Free: 800-980-ECOM (3266), Local: 630-444-0778
 Sales Support: sales@enginuitycom.com

Technical Support:

Monday through Friday, 8:00 a.m. – 4:00 p.m. CST
 Toll Free: 800-841-1005
 E-mail: support@enginuitycom.com

Enginuity Communications

3545 Stern Avenue
 St. Charles, IL 60174

6. WARRANTY & REPAIRS

Warranty

Enginuity warrants this product for one (1) year from date of purchase. Any attempt to repair or modify the equipment by anyone other than an authorized Enginuity representative will void the warranty.

This limited warranty does not cover any losses or damages resulting from shipment to or from the customer, or from improper installation, abuse, modifications, or unauthorized repair by other than Enginuity personnel.

Repair and Return

Enginuity equipment will be repaired or replaced without cost during the warranty period if the product is defective for any reason other than abuse, improper use, or improper installation. Before returning defective equipment, first request a Return Material Authorization (RMA) number from Enginuity. Once an RMA number is obtained, return the unit, freight prepaid, along with a brief description of the problem, to:

Enginuity Communications
 3545 Stern Avenue
 St. Charles, Illinois 60174
 ATTN: Repair & Return Dept.

Replacements will be shipped in the fastest manner consistent with the urgency of the situation. Repair or replacement of faulty equipment beyond the warranty period is available for a nominal charge.

7. SPECIFICATIONS

Enclosure

Part Number	LOCDROP-EN
Description	Enclosure
Dimensions	9 x 4 x 2.4 inches (L x W x H)
Weight	0.84 pounds
Operating Temperature	-40 to 85°C

Spare Parts Kits

Part Number	LD-RNGK2-20
Description	20 sets of replacement nut/grommet kits. Each kit includes: 2 each small hole port nut and round grommet 2 each large hole port nut and oval grommet

Optional Strand Mount Kit

Part Number	LOCDROP-SM-10 (10 pack each containing two brackets, two strain relief boots, and mounting hardware)
Description	Strand mounting kit for the LOC-DROP enclosure (2 kits are needed to support the LOCDROP-2SCAPC)
Dimensions per bracket	5.9 x 0.55 x 1.6 inches (L x W x D) When installed the LOC-DROP enclosure sits approximately 4 inches below the strand.
Weight (2 brackets plus hardware)	0.32 pounds