

## OnSite™ Wall Racks and Brackets

Compact, full-featured wall mountings for rack-based equipment

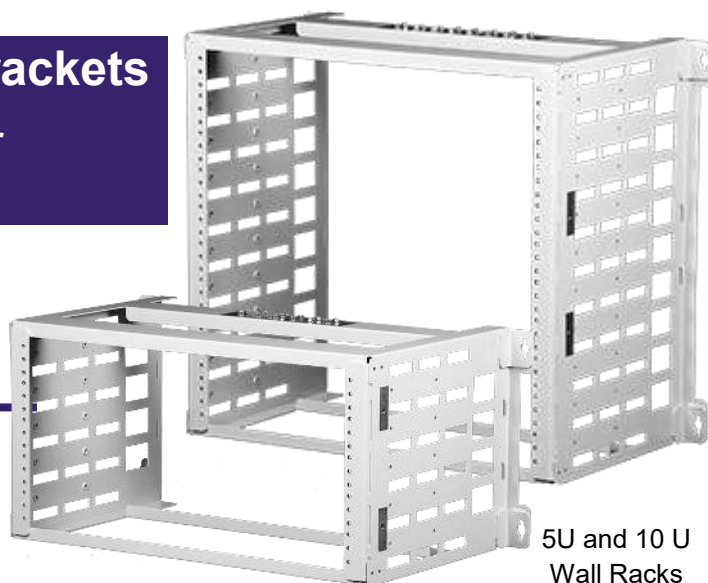

5U and 10 U  
Wall Racks

### Features

- Racks with capacity of five or ten rack units
- Wall mount brackets with capacity of three, five and seven rack units
- Greatly reduces wall-space requirements
- Efficiently manages fiber and copper cables
- Incredibly strong, NEBS compliant
- Simple to install (no assembly required)

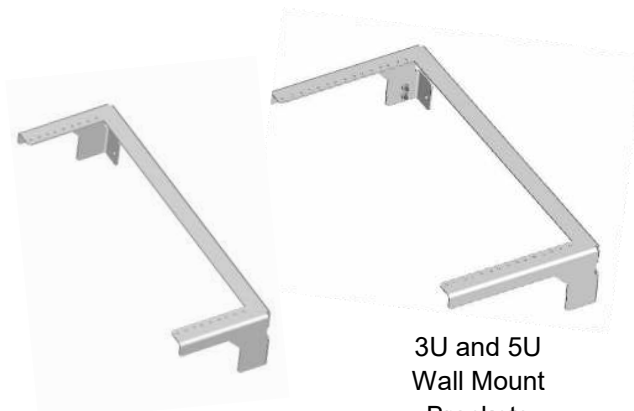

3U and 5U  
Wall Mount  
Brackets

### Rack-and-Stack or Backboard

OnSite wall racks and wall mount brackets solve a growing problem with delivery of communication services at Business locations: Where to install all that chassis-based equipment?

Our multi-position racks provide carrier-strength support for standard 19" chassis in far less space than flat mounting or floor racks. Combined with efficient cable management accessories and swing out options, each model is a great all-in-one solution for stacked chassis applications.

The wall mount brackets offer another option for 19" rack mount equipment minimizing the vertical space required.

### Carrier-class Construction

These welded wall racks and wall mount brackets require no assembly and are light enough for a single technician to easily install. Built-in dual-screw grounding points are included. All models have been tested and pass Telcordia NEBS requirements including Zone 4 seismic.

### Cable Management Options

A clean installation makes the job complete! Available cable management accessories are easy to install and allow each unit to be tailored to the application. For rear access applications, racks can be installed with wall-mounted swing-out adapters that allow racks to swing out a full 90 degrees.

## Specifications and Ordering Information

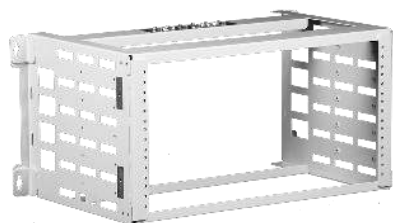

WR-5UI2



WMB-3U

Model #	Description	Height	Width	Depth	Weight	Load Capacity	Ground Points
WR-5UI2	5U wall rack for 19" equipment	11.0"	22.7"	12.6"	10.2lb	100lb	6 pairs
WR-10U	10U wall rack for 19" equipment	19.3"	22.7"	12.6"	14.0 lb	200 lb	8 pairs
WMB-3U	3U wall mount bracket	4.0"	20.2"	6.7"	2.5 lb	75 lb	1 pair
WMB-5U	5U wall mount bracket	4.0"	20.2"	10.2"	3.2 lb	75 lb	1 pair
WMB-7U	7U wall mount bracket	4.0"	20.2"	13.7"	7.0 lb	100 lb	1 pair

All models meet Telcordia NEBS compliance requirements, including Zone 4 seismic.

## Swing-out Adapters for Wall Racks



Model #	Description	Height	Width	Depth	Weight	Supported Models
SOA-5U	Swing-out adapter for 19" 5U racks	10.5"	26.5"	4.0"	13.0 lb	WR-5UI2
SOA-10U	Swing-out adapter for 19" 10U and 15U racks	19.5"	26.5"	4.0"	17.4 lb	WR-10U WR-15U

All models meet Telcordia NEBS compliance requirements, including Zone 4 seismic.

## Wall Rack Accessories



CG-5

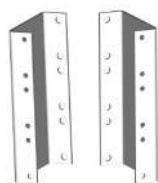

REB-3U3

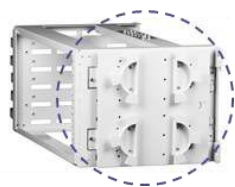

SPL-4H

Model #	Description
CG-5	Side-mounted cable guides with covers, pkg of 5
SPL-4H	Side-mounted plate with 2 split cable take-up reels
REB-3U3	Pair of 3Ux3" rack extension brackets
REB-5U3	Pair of 5Ux3" rack extension brackets
CMB-1	Front-mounted cable management bar for 19" racks
DRNG-U-2	Front-mounted universal D-ring for all racks
S03-1224108	#12-24 x 1/2" screws for rack-mount equipment; pkg of 100